

K Series drywall



About the product

Steelcraft's K Series Drywall frames are designed for light to heavy duty applications in both commercial and institutional buildings. They can be installed in rough openings after the wall has been constructed and finished. They are installed in virtually all types of buildings in all interior drywall partition locations not using baseboards. To accommodate the installation of the K Series Drywall frames on finished drywall construction, they are supplied with a KD (knock-down) corner for quick installation.

Installation

1. Installation shall conform to the published Steelcraft installation instructions, ANSI A250.11-2012 (formerly SDI 105) Recommended Erection Instructions for Steel Frames.
2. Fire Rated Assemblies must be in accordance with NFPA Pamphlet 80. The Authority Having Jurisdiction is the final authority in issues related to the installation and use of installed Fire Rated Doors.

Features and benefits

Steelcraft K Series Drywall frames include unique features which enhance long-term functionality and durability:

1. **Quick and flexible installation** of Steelcraft's K Series Drywall frames facilitates their installation in minutes and they can be relocated without damage to the frame.
2. **Die-mitered corner connections** of the K Series Drywall Frame corners lock together once the frame is installed. The tab/lock design:
 - a. prevents the head from rising
 - b. keeps the head and jamb members in alignment
 - c. keeps the miter tight
 - d. includes wedge-lock corner clips. Screws are supplied to secure miter.
3. **Sill attachment** is made through the face of the frame directly into the wall sill runner. The frame is supplied with factory countersunk holes for the screw attachment.
4. **Factory prepared** for field installed silencers.
5. **Factory applied baked-on rust inhibiting primer** in accordance with ANSI A250.10-2011.

Specification compliance

1. Overall frame construction for Steelcraft K Series Drywall frames meet the requirements of ANSI A250.8-2014 (SDI 100).
2. Hardware preparations and reinforcements are in accordance with ANSI A250.6. Locations are in accordance with ANSI/DHI A115 unless otherwise stated.

Fire ratings

The K Series Drywall frames meet the broadest fire rating requirements. They are listed for installations requiring compliance to both neutral pressure testing (ASTM E152 and UL 10B) and positive pressure standards (UL 10C). Refer to the **Fire Rated Section** of this manual for particular listings.

Applications

Steelcraft K Series Drywall frames are typically installed in wall construction types as defined in the chart below:

Frame applications			
Profile	Steel thickness	Wall construction	Typical wall anchors
K16	16 Gauge [0.053" (1.3 mm)]	Drywall partitions with wood or steel stud	Compression jamb anchor(s) with factory countersunk holes for screw attachment directly to the wall sill runner
K14	14 Gauge [0.067" (1.7 mm)]	Drywall partitions with wood or steel stud	Compression jamb anchor(s) with factory countersunk holes for screw attachment directly to the wall sill runner

Elevation

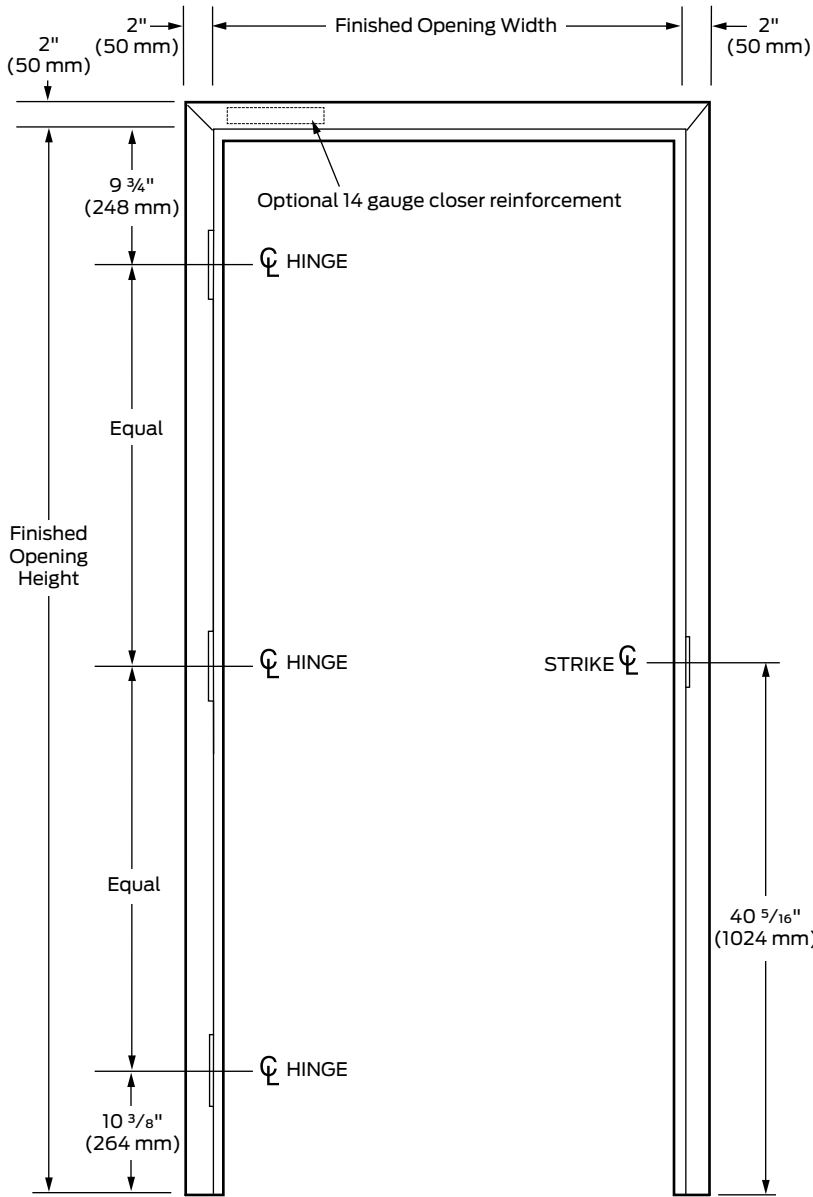

Standard Double Rabbet Frame

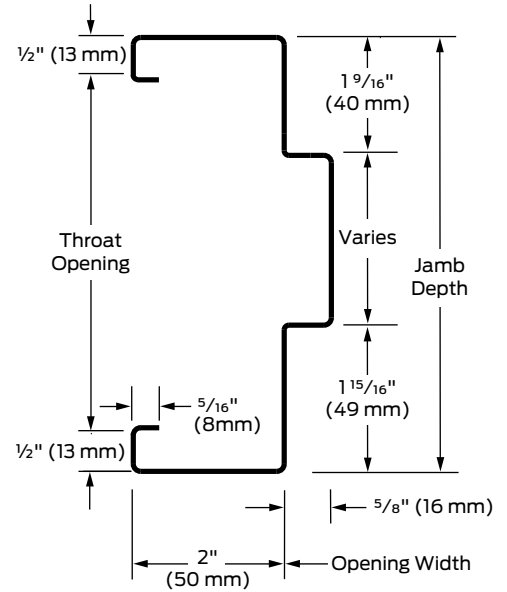

Single Rabbet Frame

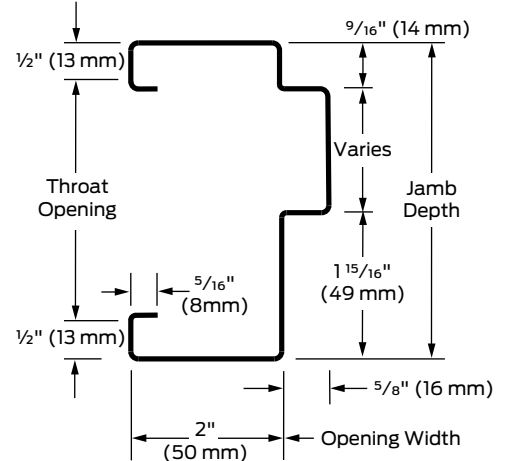

Frame sizing options										
Series	Maximum opening size		Jamb depth availability (profile)				Standard profile dimensions (variations available)			Corners
	Single	Pair	Single rabbet		Double rabbet		Face	Stop	Returns	
			Min.	Max.	Min.	Max.				Standard
K16	4'0" x 9'0" (1219 mm x 2743 mm)	8'0" x 9'0" (2439 mm x 2743 mm)	3 1/4" (83 mm)	4 3/8" (111 mm)	4 1/2" (114 mm)	14 3/4" (375 mm)	2" (51 mm)	5/8" (16 mm)	1/2" (13 mm)	DIE MITERED Wedge Lock Corner with interlocking soffit tab
K14	4'0" x 9'0" (1219 mm x 2743 mm)	8'0" x 9'0" (2439 mm x 2743 mm)	3 1/4" (83 mm)	4 3/8" (111 mm)	4 1/2" (114 mm)	14 3/4" (375 mm)	2" (51 mm)	5/8" (16 mm)	1/2" (13 mm)	DIE MITERED Wedge Lock Corner with interlocking soffit tab

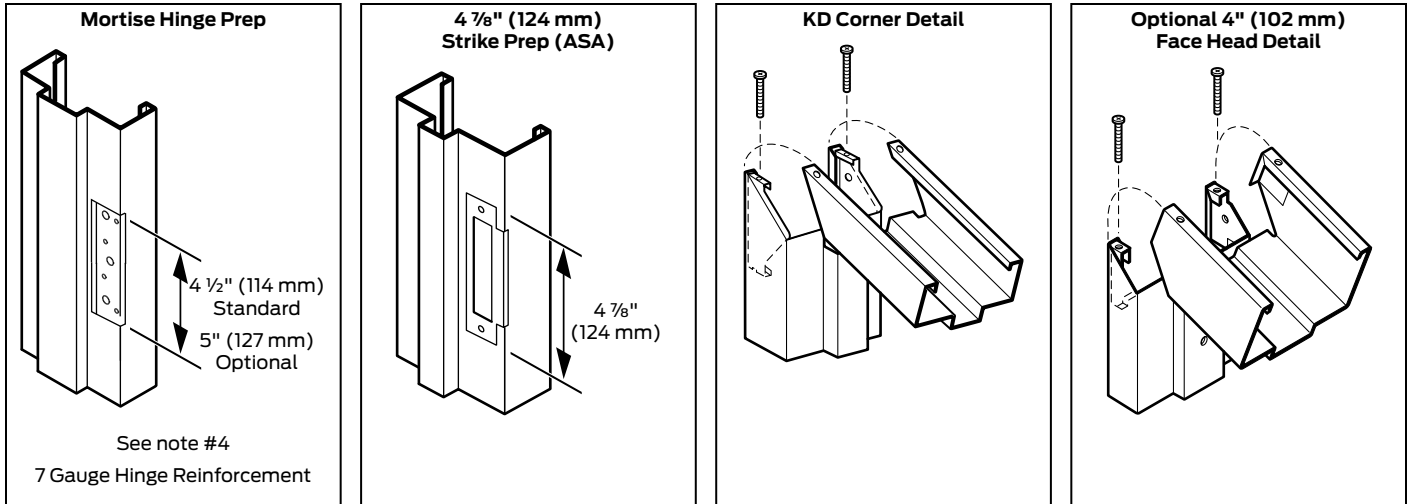

General notes

1. Variations in jamb depths available in 1/8" (3 mm) increments.
2. All K Series frames are supplied standard with field adjustable compression anchors located near the top of each jamb and factory countersunk holes for direct screw attachment to the wall runner.
 - a. The compression anchor can be easily adjusted with a screw driver or power driver.
 - b. A fastener [typically a drywall screw (by others)] is installed through the factory countersunk hole for attachment directly to the floor runner (sill) when not using wall baseboards.
3. Depending on environmental and usage conditions, the steel used can be either cold rolled or galvanized. Galvanized steel is recommended in areas of high moisture.
4. K Series frames are supplied standard with 4 1/2" standard duty hinge preps. Optional universal 4 1/2" or 5" hinge preps are available.
5. K Series with 4" heads are used mainly when installed in close proximity to a F Series or MU Series frame installed with a 4" head.

Frame options							
Series	Frame profile		Corner connections				4" (102 mm) Heads
			KD (Knock-down)		SUA (Set-up & weld)		
	Single rabbet	Double rabbet	Single rabbet	Double rabbet	Single rabbet	Double rabbet	
K16	Typically for walls less than 3 3/4" (95 mm) thick. Minimum walls thickness = 2" (51 mm)	Typically for walls less than 3 3/4" (95 mm) thickness or greater	Factory Die-Mitered, Soffit Tab included. Corner clip assembly screws required on labeled frames.		N/A		Die-mitered for use with 2" (51 mm) face jambs. Corner Clip assembly screws required.
K14							

N/A - Not Available

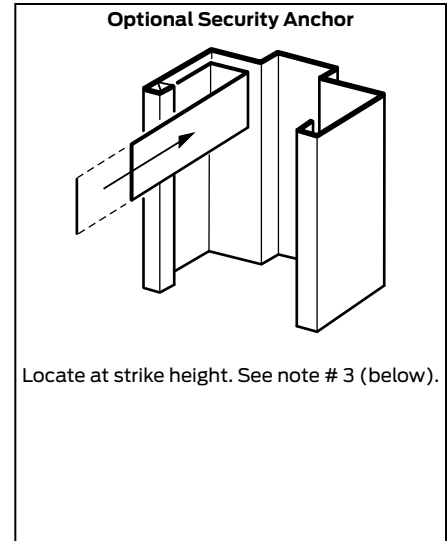
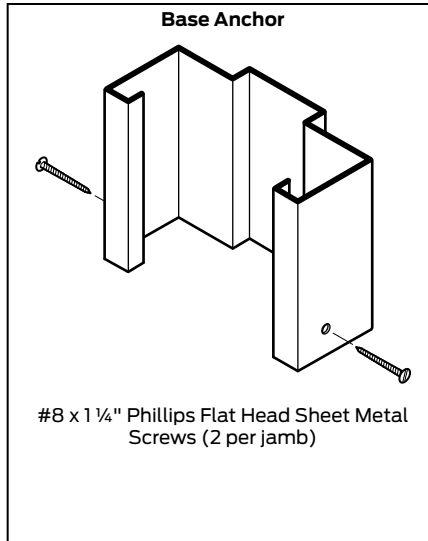
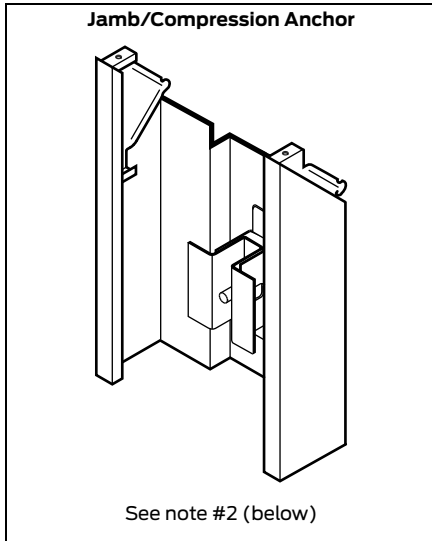

Anchoring and installation notes

- K Series Drywall frames** are supplied with field adjustable compression anchors in each jamb. The base of each jamb is anchored to the wall by installing screws through the factory prepared anchor holes. K Series frames are designed especially for use in applications not using base boards.
- For anchoring applications, refer to the Frames: Anchoring systems section of this manual.**
- Optional security anchor:** Security anchors are recommended in frames over 8'0" (2438 mm) high or in frames installed in areas where security is a priority. Locate the security anchor immediately above or below the strike reinforcements, and on both faces of the jamb. Anchors may be used in both the strike and hinge jamb. Also recommend to be used in the head of the frame for pairs.
- Grouting of the K Series frames** is not recommended.
- Installation shall conform to the published Steelcraft installation instructions, SDI 105 Recommended Installation Instructions for Steel Frames.
- All fire rated frames must be installed in accordance with NFPA Pamphlet 80 and the Authority Having Jurisdiction.

Framing applications							
Series	Steel type	Building type	Opening	Usage frequency ¹	KD Corner ⁴	SUA Corner	Applications
K16	Non-Galvannealed ²	Institutional and Commercial	Interior	Heavy to extra heavy duty	✓	N/A	Typical building conditions where base boards are not being used
	Galvannealed ³						
K14	Non-Galvannealed ²	Institutional and Commercial	Interior	Extra heavy to maximum duty	✓	N/A	Typical building conditions where base boards are not being used
	Galvannealed ³						

1 Usage frequency is based on ANSI A250.8-2014 (SDI 100)
 2 Commercial quality carbon steel
 3 Reinforcements for galvannealed frames are also galvannealed
 4 Knock-Down for field assembly prior to installation